

BALDOR® • ***RELIANCE***

Product Information Packet

ECP4409T-4

100HP, 1190RPM, 3PH, 60HZ, 444T, A44064M, TEFC

Part Detail							
Revision:	K	Status:	PRD/A	Change #:		Proprietary:	No
Type:	AC	Prod. Type:	A44064M	Elec. Spec:	A44WG3905	CD Diagram:	416820-036
Enclosure:	TEFC	Mfg Plant:		Mech. Spec:		Layout:	617427-001
Frame:	444T	Mounting:	F1	Poles:	06	Created Date:	08-10-2012
Base:		Rotation:	R	Insulation:	F	Eff. Date:	09-17-2015
Leads:	3#2					Replaced By:	
Literature:		Elec. Diagram:					

Nameplate NP3238									
CAT NO	ECP4409T-4	SPEC NO.	P44G3938						
HP	100	AMPS	119	VOLTS	460	DESIGN	B		
FRAME	444T	RPM	1190	HZ	60	AMB	40	SF	1.15
D.E. BRG.DATA	6318	O.D.E. BRG.DATA	6318	PH	3	DUTY	CONT	INSUL.CLASS	F
D.E. BRG.	90BC03J30X	TYPE	P	ENCL	TEFC	CODE	G		
O.D.E. BRG.	90BC03J30X	POWER FACTOR	82	NEMA NOM EFFICIENCY	95				
3/4 LOAD EFF.	95.3	MAX CORR KVAR	27.0	GUARANTEED EFFICIENCY	94.1				
TEMP CODE	T3	TEMP =	200						
CHP HZ	60-90	CT HZ	15-60	VT HZ	0-60				
INVERTER-TEMP-CODE	T3								
SER.NO.		MOTOR WEIGHT	1871						

Parts List		
Part Number	Description	Quantity
SA249392	SA P44G3938	1.000 EA
RA236257	RA P44G3938	1.000 EA
421948051	LABEL, MYLAR	1.000 EA
000613006PU	N/P UL CSA LABLE	1.000 EA
000692000VD	LABEL WARNING	1.000 EA
NP3238	SS CP XEX SEVERE DUTY MAIN NP	1.000 EA
089490099A	G28 BRKT 089490098WCA KB	1.000 EA
415072001B	CLAMP	1.000 EA
083199082RA	G28 SHORT FAN COVER W/BAFFLE ASSEMBLY	1.000 EA
034180014DA	KEY 1/4X1/4X1-3/4 L	1.000 EA
078548001R	FAN KB 234/150 (84) 400	1.000 EA
004824015A	GREASE POLYREX EM	1.160 LB
032018020FK	HHCS 3/4-10X2-1/2 PLTD.	4.000 EA
032018008CK	HHCS 3/8-16X1L PLATED	4.000 EA
032018030DK	HHCS 1/2-13X3-3/4 PLTD.	3.000 EA
415096002A	CPLG 1/8 HEX TYPE	1.000 EA
410700004A	WSHR	1.000 EA
034017014AB	LCKW 3/8 STD. PLATED	4.000 EA
034530064AB	P/NIP 1/8X8" GALV.	1.000 EA
089490099A	G28 BRKT 089490098WCA KB	1.000 EA
032018020FK	HHCS 3/4-10X2-1/2 PLTD.	4.000 EA
032018030DK	HHCS 1/2-13X3-3/4 PLTD.	3.000 EA
076863000C	+CBCST BLKT - 440	1.000 EA
076864000A	CB CVRCST BLKT - 440	1.000 EA

Parts List (continued)		
Part Number	Description	Quantity
415915007G	GASK, LAC	1.000 FT
067053001C	GASK 440	1.000 EA
032018008DK	HHCS 1/2-13X1 PLATED	4.000 EA
415000103D	T/LUG #4AWG-1/0AWG W/HOLE FOR .250 BOLT	1.000 EA
406099000A	PLUG - FAN COVER 320-440	1.000 EA
033512006LB	HHTTS 1/4-20X3/4 PLTD.	1.000 EA
004824003AJD	WILKO 778.50 BLUE GREEN - 55 GAL DRUMS	0.250 GA
033775004EA	DRSCR #6-1/4 304 S.S.	2.000 EA
034180054KA	KEY 7/8X7/8X6-3/4 L	1.000 EA
034690005AB	PPLG 3/4 PLATED	2.000 EA
418151014G	RETAIN RING	1.000 EA
032018004BK	HHCS 5/16-18X1/2 PLATED	3.000 EA
415096002A	CPLG 1/8 HEX TYPE	1.000 EA
032018006BK	HHCS 5/16-18X3/4 PLATED	3.000 EA
702623013A	THERMAL BARRIER -- G28 -- BRACKET MTD	1.000 EA
034017013AB	LCKW 5/16 STD. PLATED	3.000 EA
034530044AB	P/NIP 1/8X5-1/2L GALV.	1.000 EA
032620016LA	SOCKET SET SCREW-449	3.000 EA
000692000FF	N/P	1.000 EA
034631002AB	BUSH 1/4 TO 1/8 PLTD.	1.000 EA
034530064BB	P/NIP 1/4X8 PLATED	1.000 EA
PK5004A09	BASE 48 X 39-1/4 STACK 2 X 4 RUUNER	1.000 EA
415045002A	SLGR	1.000 EA
034631002AB	BUSH 1/4 TO 1/8 PLTD.	1.000 EA

Product Information Packet: ECP4409T-4 - 100HP,1190RPM,3PH,60HZ,444T,A44064M,TEFC

412118006A	DRAIN	1.000 EA
412118006A	DRAIN	1.000 EA
034530044BB	P/NIP 1/4X5-1/2L PLT	1.000 EA
406056007A	GASKET, 440	1.000 EA
032018008BK	HHCS 5/16-18X1L PLATED	4.000 EA
418150003A	GREASE FITTING CAP	1.000 EA
035000001A	ALFTG 1/8" 1610-BL	1.000 EA
418150003A	GREASE FITTING CAP	1.000 EA
035000001A	ALFTG 1/8" 1610-BL	1.000 EA
415045002A	SLGR	1.000 EA
LB1449	DIV-2/NEC WARNING LABEL	1.000 EA
035000001G	GREASE RELIEF FITTING, ALEMITE 317400	1.000 EA
035000001G	GREASE RELIEF FITTING, ALEMITE 317400	1.000 EA

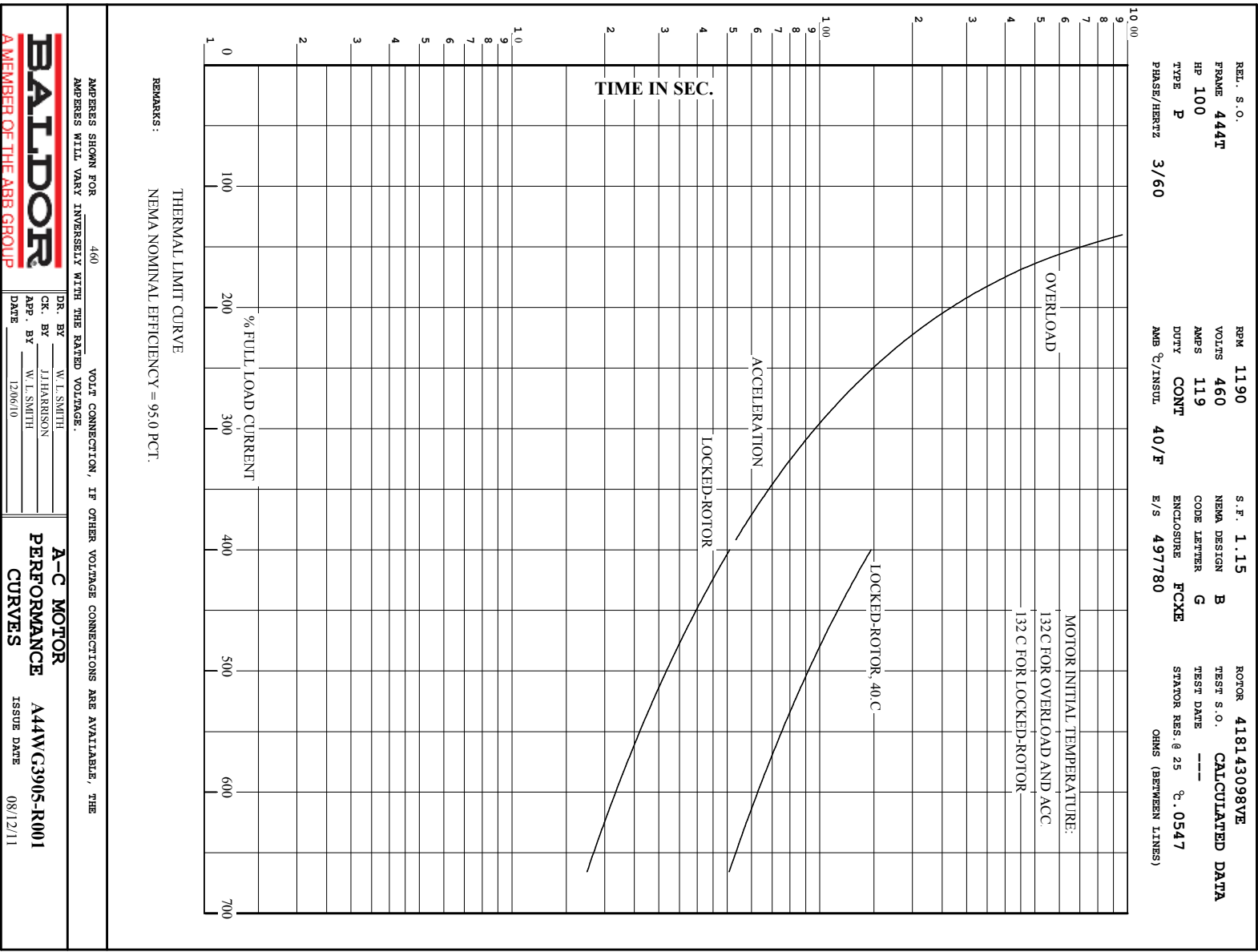

DR. BY W. L. SMITH
 CK. BY J. HARRISON
 APP. BY W. L. SMITH
 DATE 12/6/10

**A-C MOTOR
 PERFORMANCE
 CURVES**

A44W/C3905-R001
 ISSUE DATE 08/12/11

REL. S.O.	FRAME	HP	TYPE	PHASE/HERTZ	RPM	VOLTS
	444T	100	P	3/60	1190	460
AMPS	DUTY	AMB °C/INSUL.	S.F.	NEMA DESIGN	CODE LETTER	ENCL.
119	CONT	40/F	1.15	B	G	FCXE
E/S	ROTOR	TEST S.O.	TEST DATE	STATOR RES. @25 °C OHMS (BETWEEN LINES)		
497780	418143098VE	---	---	.0547		

PERFORMANCE

LOAD	HP	AMPERES	RPM	POWER FACTOR %	EFFICIENCY %
NO LOAD	0	39.4	1200	4.00	0
1/4	25.0	55.3	1197	45.8	92.6
2/4	50.0	72.2	1194	68.3	95.0
3/4	75.0	94.2	1191	78.2	95.3
4/4	100	119	1188	82.5	95.0
5/4	125	147	1184	84.3	94.4

SPEED TORQUE

	RPM	TORQUE % FULL LOAD	TORQUE LB.-FT.	AMPERES
LOCKED ROTOR	0	139	614	723
PULL UP	168	124	548	710
BREAKDOWN	1146	263	1165	433
FULL LOAD	1188	100	442	119

AMPERES SHOWN FOR 460. VOLT CONNECTION. IF OTHER VOLTAGE CONNECTIONS ARE AVAILABLE, THE AMPERES WILL VARY INVERSELY WITH THE RATED VOLTAGE

REMARKS: CALCULATED DATA
NEMA NOMINAL EFFICIENCY = 95.0 PCT.

 <p>A MEMBER OF THE ABB GROUP</p>	DR. BY <u>W. L. SMITH</u> CK. BY <u>J. J. HARRISON</u> APP. BY <u>W. L. SMITH</u> DATE <u>12/06/10</u>	A-C MOTOR PERFORMANCE DATA A44WG3905-R001 ISSUE DATE 08/12/11
---	---	--

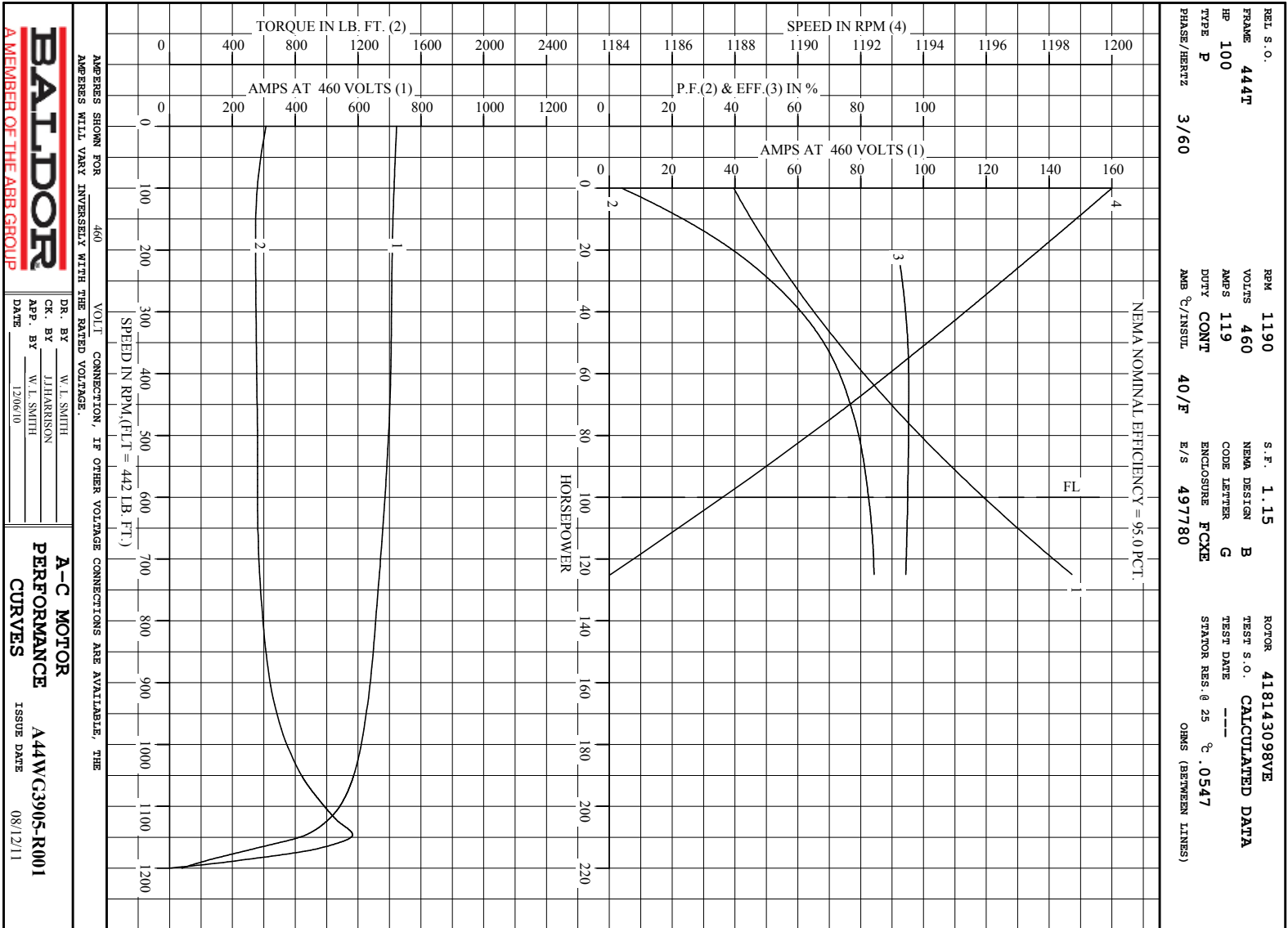

BALDOR
A MEMBER OF THE ABB GROUP

APPROX SHOWN FOR 460 VOLTS WILL VARY INVERSELY WITH THE RATED VOLTAGE.

DR. BY W. L. SMITH
 CK. BY J. HARRISON
 APP. BY W. L. SMITH
 DATE 12/06/10

A-C MOTOR PERFORMANCE CURVES
 A44WC3905-R001
 ISSUE DATE 08/12/11

Printed on 3/21/15 9:12 @ ragsun

617427-001

DUTY MASTER ALTERNATING CURRENT MOTORS

SQUIRREL-CAGE INDUCTION

ENCLOSURE: TOTALLY ENCLOSED

FRAME G445T ABOVE NEMA RATINGS

COOLING: FAN COOLED

MOUNTING: FOOT

INCLUDES 444T FRAME MOUNTING HOLES

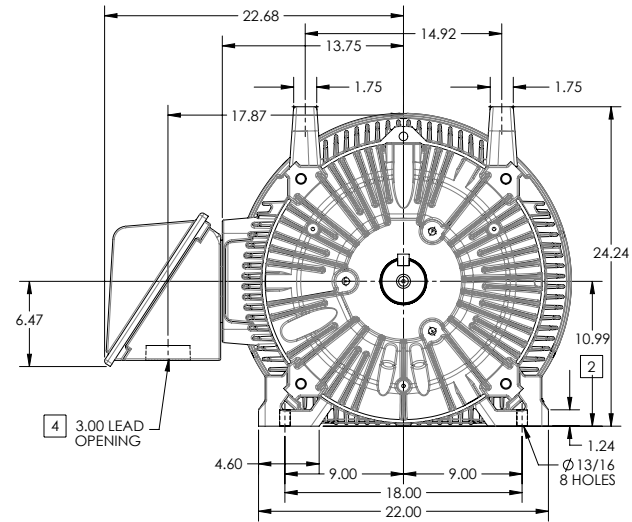
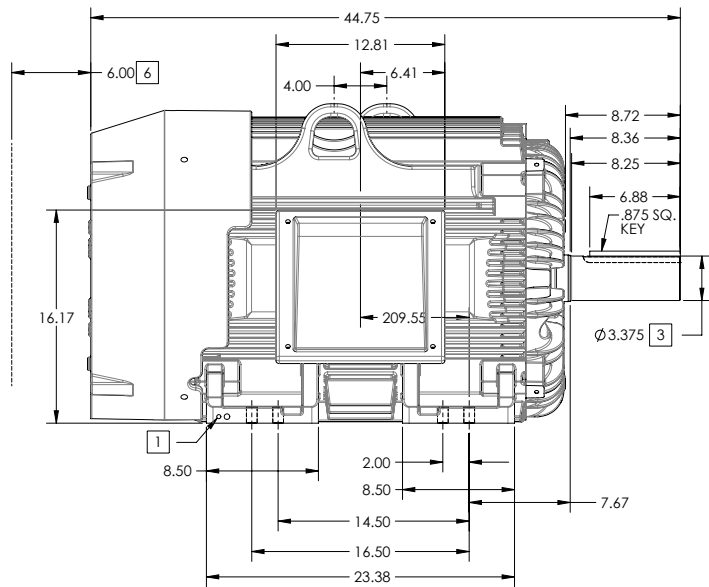

1. GROUND HOLES QTY 1 1/2-13 TAP; QTY 1 3/8-16 TAP
2. VARIES +.00,-.06
3. VARIES +.00,-.001
4. ON STANDARD MOTORS THIS IS CONDUIT SIZE. ON XT AND CORROSION PROOF MOTOR THIS IS PIPE TAP.
5. MOTOR WEIGHTS MAY VARY BY 15% DEPENDING ON RATING.
6. OBSTRUCTION MUST NOT ENCROACH ON AIR INLET

CONDUIT BOX LOCATED ON OPPOSITE SIDE WHEN F-2.
IF MOUNTING CLEARANCE DETAILS ARE REQUIRED, CONSULT FACTORY.
MAXIMUM PERMISSIBLE SHAFT RUNOUT WHEN MEASURED AT END OF STANDARD SHAFT EXTENSION IS .003" T.I.R. TO 5 INCH DIA.

[5] WEIGHT (LBS): 2130

DRIVE END AIR DEFLECTOR IS ONLY INCLUDED WHEN NECESSARY.

DIMENSIONS ARE IN INCHES; SEE SHEET 2 FOR DIMENSIONS IN MILLIMETERS

CUSTOMER IS RESPONSIBLE FOR DETERMINING THAT MOTOR PERFORMANCE IS SUITABLE IN THE APPLICATION.

SHEET NUMBER
1 OF 2

100-2727-119

REV. DESC SHEET 2 NEEDS METRIC FOOT HOLE DIMENSION			
REV: E	VERSION: 05	REVISED: 09-22-56 06/12/2014	TDR: 00000857938
MODEL NO. 617427-001			REF:
BY: RAGRA	Material:		

BALDOR

G445T444T STD - FOOTED - SIDE/CENTER CB

617427-001

617427-001

DUTY MASTER ALTERNATING CURRENT MOTORS

SQUIRREL-CAGE INDUCTION

ENCLOSURE: TOTALLY ENCLOSED

FRAME G445T ABOVE NEMA RATINGS

COOLING: FAN COOLED

MOUNTING: FOOT

INCLUDES 444T FRAME MOUNTING HOLES

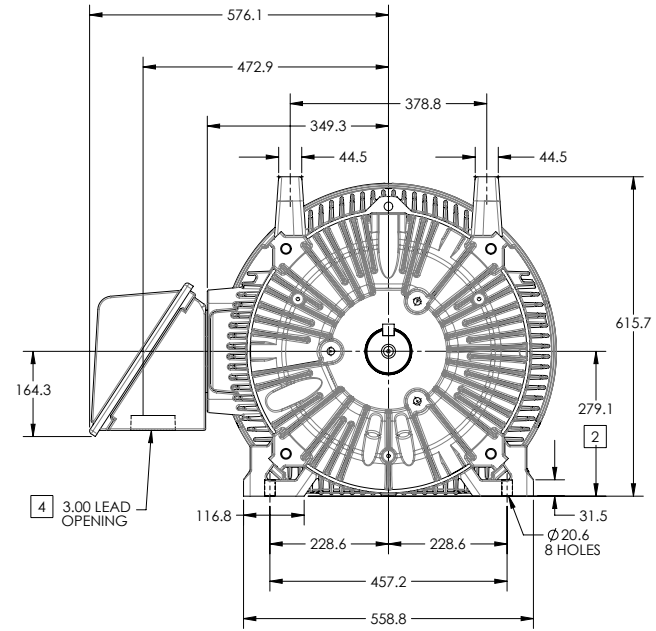
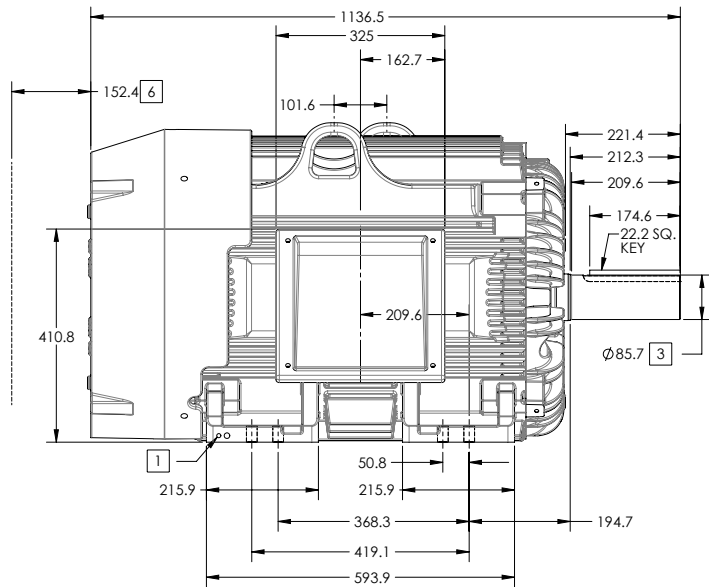

1. GROUND HOLES QTY 1 1/2-13 TAP; QTY 1 3/8-16 TAP
2. VARIES +0,-1.5
3. VARIES +.00,-.03
4. ON STANDARD MOTORS THIS IS CONDUIT SIZE. ON XT AND CORROSION PROOF MOTOR THIS IS PIPE TAP.
5. MOTOR WEIGHTS MAY VARY BY 15% DEPENDING ON RATING.
6. OBSTRUCTION MUST NOT ENCROACH ON AIR INLET

CONDUIT BOX LOCATED ON OPPOSITE SIDE WHEN F-2.
IF MOUNTING CLEARANCE DETAILS ARE REQUIRED, CONSULT FACTORY.
MAXIMUM PERMISSIBLE SHAFT RUNOUT WHEN MEASURED AT END OF STANDARD SHAFT EXTENSION IS .08 MM T.I.R. TO 127 MM DIA.

[5] WEIGHT (KGS): 970

DRIVE END AIR DEFLECTOR IS ONLY INCLUDED WHEN NECESSARY.

DIMENSIONS ARE IN MILLIMETERS; SEE SHEET 1 FOR DIMENSIONS IN INCHES

CUSTOMER IS RESPONSIBLE FOR DETERMINING THAT MOTOR PERFORMANCE IS SUITABLE IN THE APPLICATION.

SHEET NUMBER
2 OF 2

100-LCP119

REV. DESC SHEET 2 NEEDS METRIC FOOT HOLE DIMENSION			
REV: E	VERSION: 05	REVISED: 09-22-56 06/12/2014	TDR: 00000857938
MODEL NO. 617427-001		REF:	
BY: RAGRA	Material:	C	

BALDOR

G445T444T STD - FOOTED - SIDE/CENTER CB

617427-001

416820-036

A-C MOTOR
 CONNECTION DIAGRAM
 STANDARD 3 LEAD CONNECTED

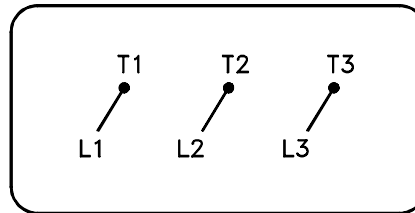

(N.P. 1575-BA)

416820-036

REV. DESC: LOADED TO BUS, C/R 335225		
REV. LTR: -	VERSION: 00	TDR: 000000538207
FILE: \MGA\00000\682	REVISED: 11:54:06 04/30/2010	
MTL: -	BY: RAGRA	

BALDOR

CONN DIAG - STANDARD 3 LEAD

SH 1 of 1