

# **BALDOR® • RELIANCE**

## **Product Information Packet**

# **AOM3714T**

**10HP,1770RPM,3PH,60HZ,215T,3740M,TENV,F1**

Part Detail							
Revision:	G	Status:	PRD/A	Change #:		Proprietary:	No
Type:	AC	Prod. Type:	3740M	Elec. Spec:	37WGS275	CD Diagram:	CD0005
Enclosure:	TEAO	Mfg Plant:		Mech. Spec:	37F359	Layout:	37LYF359
Frame:	215T	Mounting:	F1	Poles:	04	Created Date:	07-18-2007
Base:	RG	Rotation:	R	Insulation:	F	Eff. Date:	07-27-2015
Leads:	9#14 36" LG Y					Replaced By:	
Literature:		Elec. Diagram:					

<b>Nameplate NP1256L</b>							
CAT.NO.	AOM3714T						
SPEC.	37F359S275H1						
HP	10 AIR OVER						
VOLTS	208-230/460						
AMP	28-27/13.5						
RPM	1770						
FRAME	215T	HZ	60	PH	3		
SER.F.	1.15	CODE	K	DES	A	CLASS	F
NEMA-NOM-EFF	89.5	PF	77				
RATING	40C AMB-CONT						
CC		USABLE AT 208V					
DE	6307	ODE	6206				
ENCL	TEAO	SN					
	1700 FPM AT 170CFM						

Parts List		
Part Number	Description	Quantity
SA160713	SA 37F359S275H1	1.000 EA
RA149298	RA 37F359S275H1	1.000 EA
HW3200A01	3/8-16X3/4 I-BLT WELDED F/S	1.000 EA
37CB3004	37 CB CASTING W/1.09 LEAD HOLE @ 6:00	1.000 EA
37GS1000SP	GASKET, CONDUIT BOX STD., .06 THICK LEXI	1.000 EA
10XN2520A10	1/4-20X 5/8 HEX HD X	2.000 EA
HW1001A25	LOCKWASHER 1/4, ZINC PLT .493 OD, .255 I	2.000 EA
XY3118A12	5/16-18 HEX NUT DIRECTIONAL SERRATION	4.000 EA
37CB4516	LIPPED LID FOR 37 FRAME NEC KOBX	1.000 EA
37GS1008SP	37 GS FOR CB LID - LEXIDE	1.000 EA
11XW1032G06	10-32 X .38, TAPTITE II, HEX WSHR SLTD U	1.000 EA
37EP3101A02	FR ENDPLATE, 37L&M-TENV MTR, MACH	1.000 EA
HW4500A01	1641B(ALEMITE)400 UNIV, GREASE FITT	1.000 EA
HW5100A06	W2420-025 WVY WSHR (WB)	1.000 EA
37EP3100A09	PU ENDPLATE, MACH	1.000 EA
HW4500A01	1641B(ALEMITE)400 UNIV, GREASE FITT	1.000 EA
10XN2520A28	1/4-20X 1 3/4 HEX HD	4.000 EA
HW1001A25	LOCKWASHER 1/4, ZINC PLT .493 OD, .255 I	4.000 EA
51XW0832A07	8-32 X .44, TAPTITE II, HEX WSHR SLTD SE	4.000 EA
HW2501F21	KEY, 5/16 SQ X 2.375	1.000 EA
HA7000A02	KEY RETAINER RING, 1 1/8 DIA, 1 3/8 DIA	1.000 EA
85XU0407S04	4X1/4 U DRIVE PIN STAINLESS	2.000 EA
LB1115N	LABEL,LIFTING DEVICE (ON ROLLS)	1.000 EA
MJ1000A75	GREASE, POLYREX EM EXXON (USe 4824-15A)	0.050 LB

<b>Parts List (continued)</b>		
<b>Part Number</b>	<b>Description</b>	<b>Quantity</b>
MG1000G27	MED CHARCOAL METALLIC GREY	0.028 GA
HA3104A17	5/16-18X13.250 T-BLT/OHIO	4.000 EA
LC0005E01	CONN.DIA./WARNING LABEL (LC0005/LB1119N)	1.000 EA
NP1256L	ALUM UL CSA CC	1.000 EA
36PA1001	PKG GRP, PRINT PK1017A06	1.000 EA
MN416A01	TAG-INSTAL-MAINT no wire (1200/bx) 11/14	1.000 EA

<b>Accessories</b>		
<b>Part Number</b>	<b>Description</b>	<b>Multiplier</b>
37-3301	C FACE KIT	P1

**AC Induction Motor Performance Data**

Record # 37123 - Typical performance - not guaranteed values

<b>Winding:</b> 37WGS275-R003	<b>Type:</b> 3740M	<b>Enclosure:</b> TEAO
-------------------------------	--------------------	------------------------

Nameplate Data				460 V, 60 Hz: High Voltage Connection	
Rated Output (HP)	10 AIR OVER			Full Load Torque	29.5 LB-FT
Volts	208-230/460			Start Configuration	direct on line
Full Load Amps	28-27/13.5			Breakdown Torque	121 LB-FT
R.P.M.	1770			Pull-up Torque	53.6 LB-FT
Hz	60	Phase	3	Locked-rotor Torque	68.8 LB-FT
NEMA Design Code	A	KVA Code	K	Starting Current	107 A
Service Factor (S.F.)	1.15			No-load Current	7.31 A
NEMA Nom. Eff.	89.5	Power Factor	77	Line-line Res. @ 25°C	1.15 Ω
Rating - Duty	40C AMB-CONT			Temp. Rise @ Rated Load	78°C
S.F. Amps				Temp. Rise @ S.F. Load	92°C
				Rotor inertia	0.984 LB-FT <sup>2</sup>

**Load Characteristics 460 V, 60 Hz, 10 HP**

% of Rated Load	25	50	75	100	125	150	S.F.
Power Factor	36	58	70	77	81	84	79
Efficiency	81.5	88.6	89.4	89.6	89	88.1	89.2
Speed	1793	1785	1777	1769	1760	1751	1764
Line amperes	7.82	9.21	11	13.5	16.2	19	15.1

Performance Graph at 460V, 60Hz, 10.0HP Typical performance - Not guaranteed values

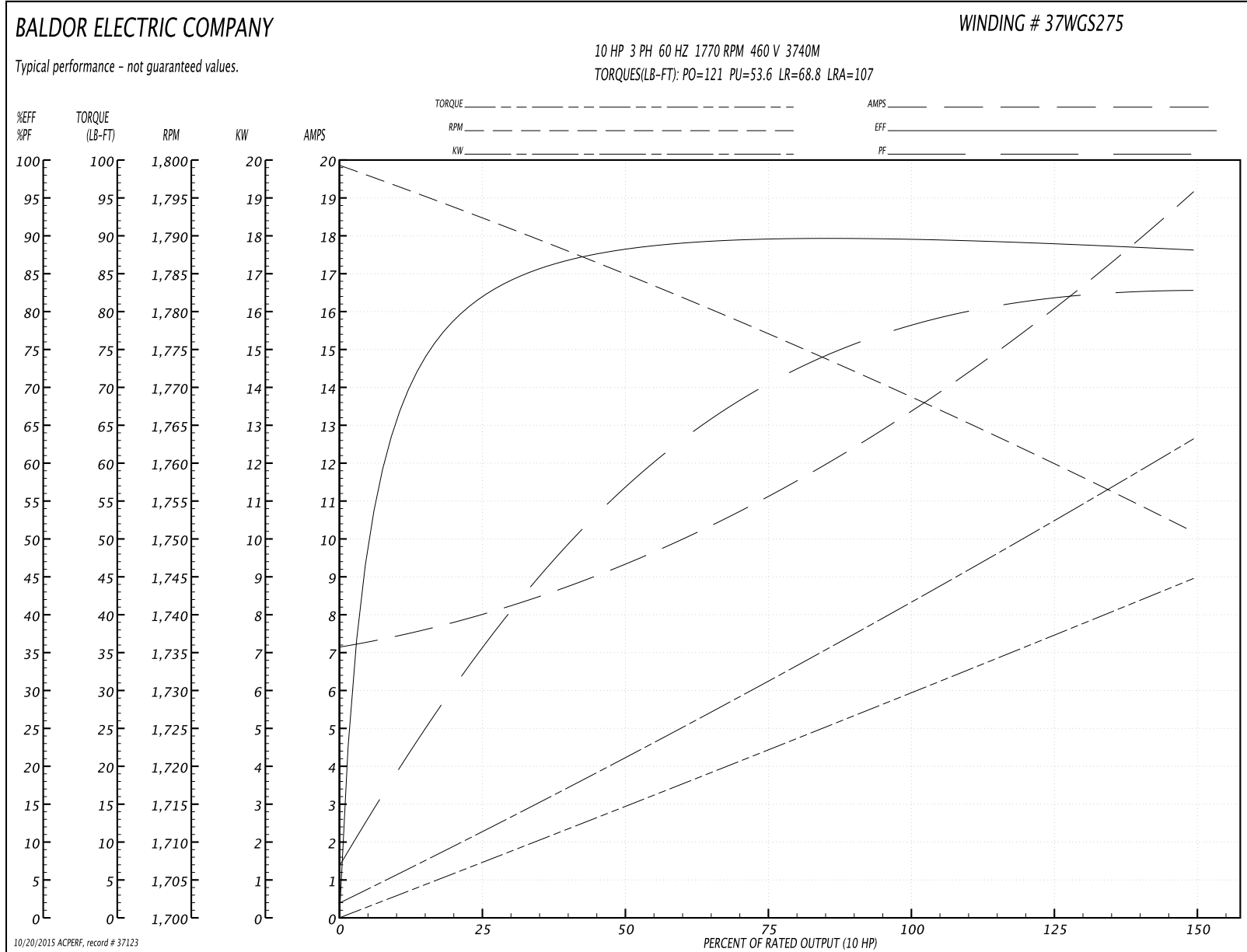



37LYF359

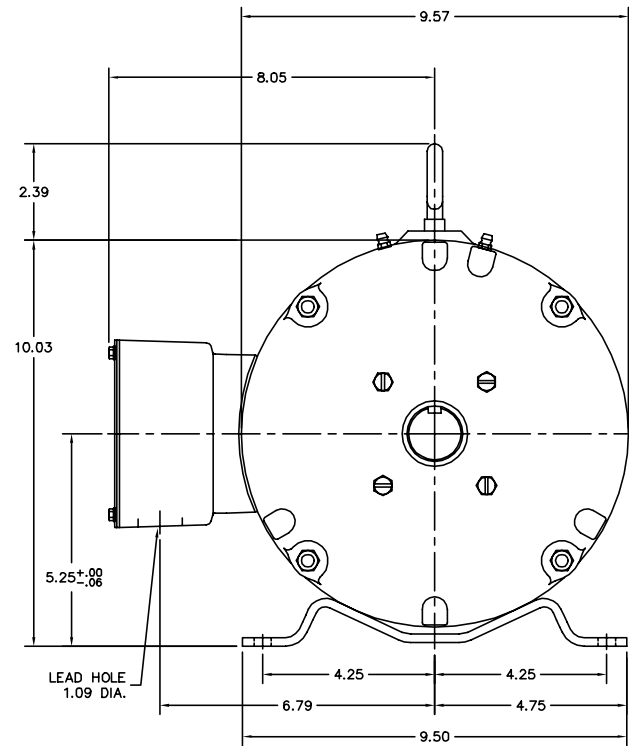
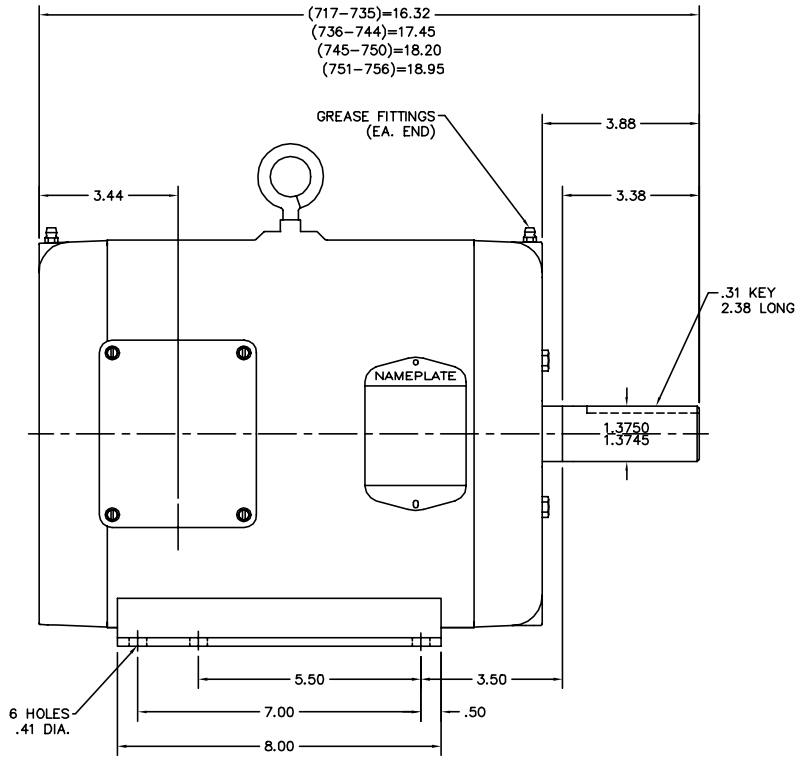

CUSTOMER IS RESPONSIBLE FOR DETERMINING THAT MOTOR PERFORMANCE IS SUITABLE IN THE APPLICATION.

REV. DESC: UPDATED STACKS		
REV. LTR: G	VERSION: 01	TDR: 000000380140
FILE: \AAA\00010\082	REVISED: 11:13:16 11/01/2005	BY: ENSHAB0
MTL: -		

**BALDOR ELECTRIC Co.**

HORZ 213-5T TENV 37M W/LOCKED BRG

37LYF359

CD0005



LOW VOLTAGE (2Y)

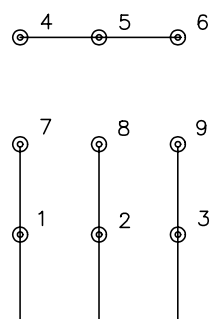

LINE

HIGH VOLTAGE (1Y)

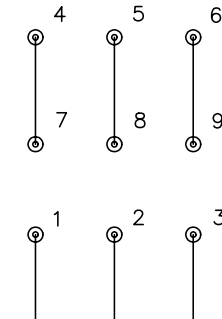

LINE

NOTES:

1. INTERCHANGE ANY TWO LINE LEADS TO REVERSE ROTATION.
2. OPTIONAL THERMOSTATS ARE PROVIDED WHEN SPECIFIED.
3. ACTUAL NUMBER OF INTERNAL PARALLEL CIRCUITS MAY BE A MULTIPLE OF THOSE SHOWN ABOVE.
4. LEAD COLORS ARE OPTIONAL. LEADS MUST ALWAYS BE NUMBERED AS SHOWN.

REV. DESC: REVISE TO SHOW OPTIONAL COLORS			
REV. LTR: E	BY: JLP	REVISED: 01/19/99 10:15	TDR: 0171435
90000		FILE: AAA00005140	MDL: -
		MTL: -	

**BALDOR ELECTRIC Co.**

3PH, DV, 9 LEADS

CD0005